



# Vandera Emergency Bulkhead



The Vandera Emergency Bulkhead with unique lens designed to diffuse LEDs delivers robust, reliable illumination for walkways, car parks, underpasses and railway stations.

- Vandal-resistant IK10++ design
- Tested against impact to 125J for the most demanding applications
- Rear cable entry, side entry available upon request

## Applications



Residential



Campus



Rail



Car Parks



Public Realm

## Luminaire Specification

- Anti-vandal emergency illuminated bulkhead luminaire

## Colour Temperature

- 4000K
- 3000K (5% lower lumen output)

## Electrical Specification

- Output Power (Watts): 2-19
- Electrical Class: Class 1

## Certification

- CE, UKCA

## Mounting

- Suitable for rear cable entry
- Side entry available upon request

## Materials

- Body: Zinc coated steel
- Glazing: 4mm opal polycarbonate

## Lumen Range (Lumens)

- 300-1900

## Colour Rendering Index

- 80Ra

## Max Luminaire Efficacy

- <125lm/W

Weight 2kg

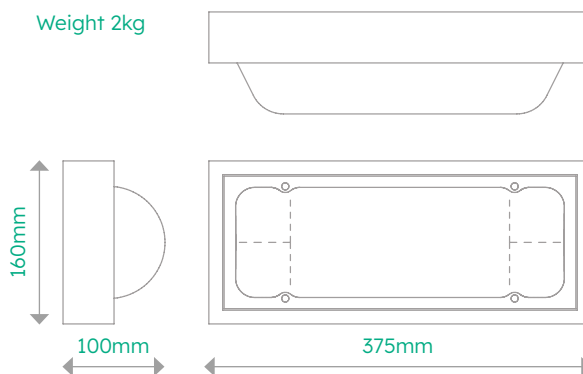

## Control

- Integral emergency
- Integral self-test emergency
- Integral DALI emergency
- Emergency high output
- Central battery inverter
- DALI
- Switch dim
- Microwave sensor

## Finish

- Polyester powder coat

## Colour

- RAL 9005 Black • RAL 7016 Grey
- Other RAL colours on request

## Operating Temperature

- -30°C to +50°C

## Warranty

- 5 years (standard)

## Durability

- IP65 Ingress Protection
- IK10++ Impact Resistance

